



radiantlighting

## WATERPROOF TRANSFORMER ACCESSORIES

BY HUNZA

PROJECT	
TYPE	
NOTES	

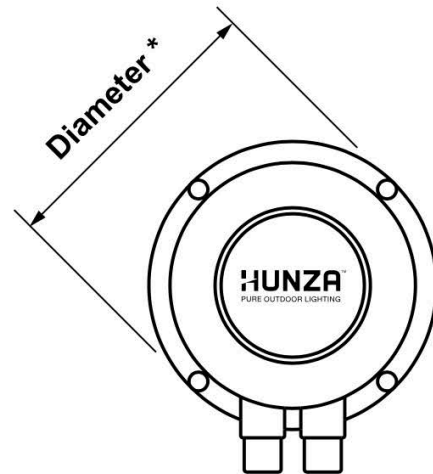

<b>PRODUCT NAME</b>	Waterproof Transformer
<b>DESIGNER</b>	HUNZA
<b>MANUFACTURER</b>	HUNZA
<b>PRODUCT CODE</b>	72-T30WP (30VA)      72-T200WP (200VA) 72-T50WP (50VA)      72-T300WP (300VA) 72-T100WP (100VA)
<b>CATEGORY</b>	Accessories / Outdoor
<b>MATERIAL</b>	Case: Glass filled UV stabilised Nylon 66 Transformer: Encapsulated Toroidal
<b>MOUNTING</b>	Wall or Burial

<b>VOLTAGES</b>	Primary - 120 volt 60Hz or 240 volt 50Hz. Secondary - Multi Tap 12, 13 volts
<b>WATTAGES</b>	30W   50W   100W   200W   300W
<b>IP</b>	67
<b>ORIGIN</b>	New Zealand
<b>WARRANTY</b>	5 Years

Watts (VA Rating)	IP Rating	Diameter * (mm)
30W	67	110
50W	67	152
100W	67	152
150W	67	175
200W	67	175
300W	67	175