

# EDGE 100

A clean finish every time - the EDGE 100 downlight features a wider trim for ease of install, especially when recessed into concrete ceilings. Utilising advanced LED engines to achieve unmatched illumination with a fraction of the energy.



## FEATURES

- + Adjustable head up to 25°.
- + Precision reflector with clear lens – for better light distribution.
- + Specially designed heat sink – for class leading heat dissipation.
- + Deep set lamp position – for visual comfort and glare control.
- + Next-Generation LED chip technology.



## LUMINAIRE OPTIONS

### LED Options

15W <b>STANDARD</b>	12W	10W
1320 lm (3000K) 1270 lm (4000K)	1105 lm (3000K) 1150 lm (4000K)	960 lm (3000K) 1000 lm (4000K)

### Beam Options

60° <b>STANDARD</b>	36°	24°	15°
---------------------	-----	-----	-----

## GENERAL SPECIFICATIONS

Efficacy	Up to 95 lm/W
Colour Temperature	<input type="checkbox"/> 3000K, Warm White <input type="checkbox"/> 4000K, Cool White
Material	Powder Coated Aluminium
Finish	White   Black
CRI	92+
IP	44
Colour Deviation	SDCM ≤2
UGR	<19
Lifetime	>55,000hrs L80 B10
Warranty	7 Years

## PROJECT DETAILS

PROJECT:

TYPE:

NOTES:

## DIMENSIONS

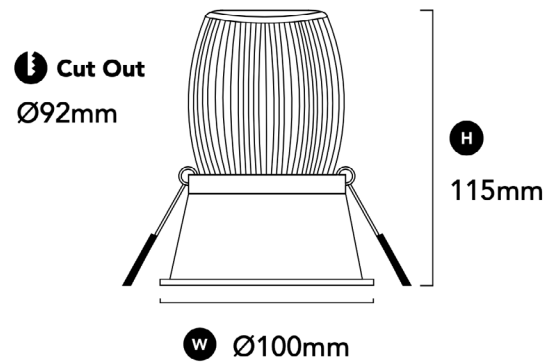

## DRIVER SPECIFICATIONS

Dimensions	L 104 x W 43 x H 24 mm
Power	250mA   300mA   350mA 240V Remote Flicker Free Dimmable Driver
Dimming	Phase Cut Dimming
Power Factor	> 0.90

DALI Dimming Available Upon Request

## PRODUCT CODES

White, 3000K	118-ED2L13W603
Black, 3000K	118-ED2L13B603
White, 4000K	118-ED2L13W604
Black, 4000K	118-ED2L13B604

## REFLECTOR CODES

36° Reflector	118-RFLP36
24° Reflector	118-RFLP24
15° Reflector	118-RFLP15