

PRO SQUARE G3

The Generation 3 FAZE PRO is a specifically designed to enhance. Utilising superior LED technology, combined with a high CRI, and a re-engineered heatsink; this series of downlights are guaranteed to bring your spaces to life, in an efficient manner.

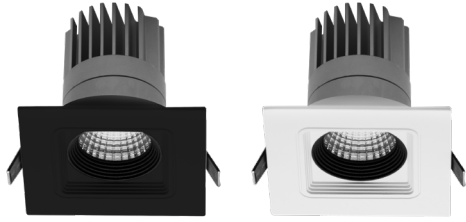

FEATURES

- + Precision reflector with clear lens – for better light distribution.
- + Specially designed heat sink – for class leading heat dissipation.
- + Deep set lamp position – for visual comfort and glare control.
- + Suitable for concrete install with concrete canister. (Ordered Separately).
- + Generation 3 Technology.



LUMINAIRE OPTIONS

LED Options

13W STANDARD	10W	8W
1400 lm (3000K) 1500 lm (4000K)	1170 lm (3000K) 1270 lm (4000K)	1025 lm (3000K) 1125 lm (4000K)

Beam Options

60° STANDARD	36°	24°	15°
---------------------	-----	-----	-----

GENERAL SPECIFICATIONS

Efficacy	Up to 127 lm/W
Colour Temperature	<input type="checkbox"/> 3000K, Warm White <input type="checkbox"/> 4000K, Cool White
Material	Powder Coated Aluminium
Finish	White Black
CRI	92+
IP	44
Colour Deviation	SDCM ≤2
UGR	<18
Lifetime	>55,000hrs L80 B10
Warranty	7 Years

PROJECT DETAILS

PROJECT:

TYPE:

NOTES:

DIMENSIONS

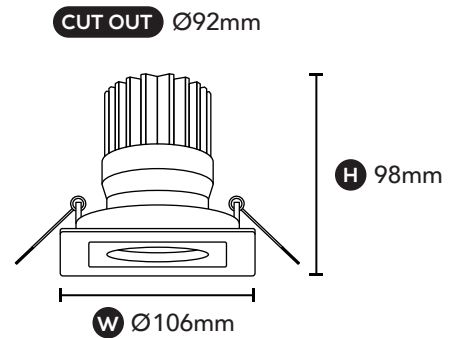

DRIVER SPECIFICATIONS

Dimensions	L 104 x W 43 x H 24 mm
Power	350mA 300mA 250mA 240V Remote Flicker Free Dimmable Driver
Dimming	Phase Cut Dimming
Power Factor	> 0.90

DALI Dimming Available Upon Request

PRODUCT CODES

White, 3000K	118-PR3LS13W603
Black, 3000K	118-PR3LS13B603
White, 4000K	118-PR3LS13W604
Black, 4000K	118-PR3LS13B604

REFLECTOR CODES

60° Lens	118-LSE360
36° Reflector	118-RFLP36
36° Lens	118-LSE336
24° Reflector	118-RFLP24
24° Lens	118-LSE324
15° Reflector	118-RFLP15
15° Lens	118-LSE315